

pole maintenance & inspection

Regular inspection and maintenance of light poles and luminaires is extremely important. Quarterly to semi-annual inspections are recommended to ensure safety. While there are many aesthetic features to be discovered during these inspections, our inspection list is limited to those items where safety is a concern. Pole and luminaire inspections should consist of (but not limited to) the following:

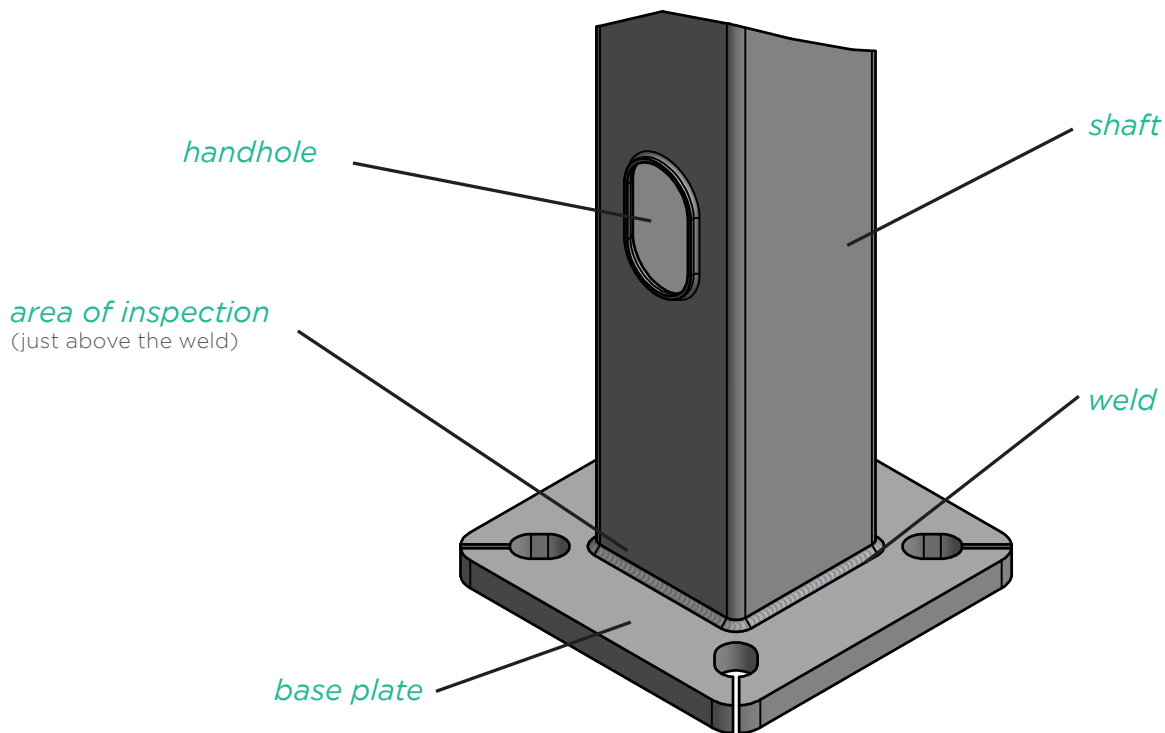

pole shaft

Visual inspection of the pole shaft for areas of rust, corrosion and any dents or signs that the structural integrity has been compromised.

brackets / arms

Visual inspection, using binoculars if necessary, of any brackets, arms or luminaires. Close inspection of any welds to ensure there is no metal fatigue. Again, looking for any signs that the structural integrity of the bracket and the method of attachment has been compromised.

handhole covers / base covers / nut covers

Ensure that handhole covers, base covers and nut covers are securely attached.

anchor bolts

Ensure that all anchor bolt nuts are in place and securely tightened.

signs of vibration

- Noise or humming in the pole.
- Visual movement of the luminaire and / or pole.
- Loosening of attachments.
- Rust just above the weld at the base of the pole.